

自然语言处理的历史

CS224N/Ling284

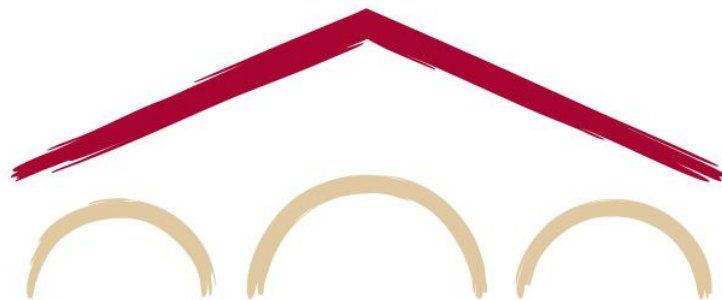

Christopher Manning

Lecture 1

Christopher D. Manning : 人类语言理解与推理

NLP 的四个时代

- **1940–1969:** 早期探索
- **1970–1992:** Hand-built symbolic NLP 系统，越来越形式化
- **1993–2012:** Statistical or Probabilistic NLP and then more general Supervised 机器学习用于 NLP
- **2013–now:** Deep Learning or Artificial 神经网络；无监督或自 有监督 NLP；强化学习

仅部分交叉的领域

- NLP / 计算语言学
- AI / 神经网络



Dædalus 151(2): 127–138 (Spring 2022)

<https://www.amacad.org/publication/human-language-understanding-reasoning>

1 . 早期探索

1940–1969

机器翻译：NLP / 计算语言学的起源

“Also knowing nothing official about, but having guessed and inferred considerable about, the powerful new mechanized methods in cryptography—methods which I believe succeed even when one does not know what language has been coded—one naturally wonders if the problem of translation could conceivably be treated as a problem in cryptography. When I look at an article in Russian, I say: ‘This is really written in English, but it has been coded in some strange symbols. I will now proceed to decode.’ ”

– Warren Weaver (1955:18, quoting a letter he wrote in 1947)





“When I look at an article in Russian, I say:
‘This is really written in English, but it has
been coded in some strange symbols. I will
现在开始解码。’ ” – Warren
Weaver, March 1947

Weaver was a mathematician & engineer known for his work as a science funder at the Rockefeller Foundation and OSR&D (US Govt WWII science funder) and for coauthoring an approachable Shannon 的信息论导论

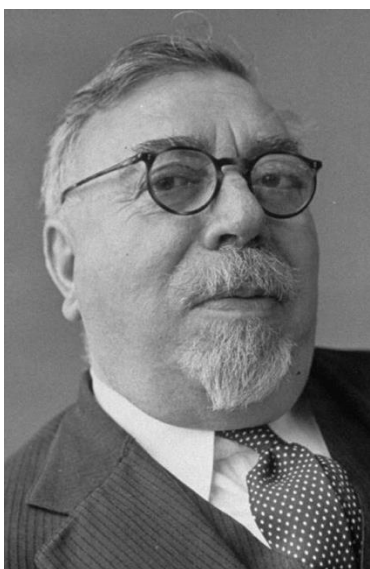

“... as to the problem of mechanical translation, I frankly am afraid that the [semantic] boundaries of words in different languages are too vague ... to make any quasi-mechanical translation scheme very hopeful.”
– Norbert Wiener, April 1947

Wiener: MIT originator of **cybernetics**, which sought to tie together communication, control, and feedback in living things and computers.

"All the News
That's Fit to Print"

The New York Times.

LATE CITY EDITION

Fair and cold today. Increasing
cloudiness and cold tomorrow.
Temperature Range Today—Max., 35; Min., 22
Temperatures Yesterday—Max., 36; Min., 26
Full U. S. Weather Bureau Report, Page 41

Copyright, 1954, by The New York Times Company.

VOL. CIII..No. 35,048.

Entered as Second-Class Matter.
Post Office, New York, N. Y.

NEW YORK, FRIDAY, JANUARY 8, 1954.

Times Square, New York 36, N. Y.
Telephone LACKAWANNA 4-1000

FIVE CENTS

PIER STRIKE CURB SOUGHT IN COURTS AS TIE-UPS SPREAD

Walkout on Another Brooklyn
Dock Stirs Fear of 'Flash'
Stoppage Throughout Port

VOTE DISPUTE CONTINUES

New Questions Delay Sending
Poll Report to Capital—City
Tightens Its Precautions

By A. H. RASKIN

Shipping employers sought court help yesterday to halt the spread of Brooklyn pier strikes before they exploded into a port-wide shutdown.

The injunction moves came after a second dock had been closed by a work stoppage. The walkout by seventy-five members of the old International Longshoremen's Association stopped loading of the British freighter City of Barcelona at Pier 2, Bush Terminal.

It occurred on the sixth day of a strike by 150 American Federation of Labor dock workers, which has prevented removal of cargo from two Isbrandtsen Line freighters at Pier 29, Brooklyn. Although the walkouts had no apparent connection with one another, shipping executives expressed fear that they might provide the spark for a general tie-up of the strife-ridden harbor.

City Widens Precautions

Mayor Wagner took new steps to perfect the city's preparations for possible violence in the event of a waterfront strike on a broad

White Miners Veto Rhodesia Color Bar

By ALBION ROSS

SPECIAL TO THE NEW YORK TIMES.
JOHANNESBURG, South Africa, Jan. 7.—White miners at the American-controlled Roan Antelope Mine in Northern Rhodesia have shaken the mining and industrial world of southern Africa by voting for removal of the color bar.

The mine's white workers, representing roughly one-fourth of the white persons in the Northern Rhodesian copper industry, voted to strike out the first clause of their agreement with the copper producers. The clause limits employment in the higher paid and more skilled jobs to white men.

In the new goldfields of Odendaalsrus, Orange Free State, Gert Lombaard, speaking for the white South African Gold Miners Union, now under Nationalist leadership, called on white miners to resist this

Continued on Page 5, Column 5

MRS. LUCE TO RUSH TO ITALY IN CRISIS

Ambassador Cuts Visit to U. S.
by Week to Report Events
—Vatican Backs Pella

SPECIAL TO THE NEW YORK TIMES.

WASHINGTON, Jan. 7.—Mrs. Clare Boothe Luce, United States Ambassador to Rome, will return to her post ahead of schedule because of the Italian Government crisis.

Mrs. Luce, who returned to Washington shortly before Jan. 1, plans to leave New York for

MAYOR ASKS STUDY OF STATE TAX SHIFT TO AID CITY INCOME

Urges Dewey to Join Move for
'Proper' Sharing of Levies
as Way to End Problems

Text of address by the Mayor
is printed on Page 14.

By PAUL CROWELL

Mayor Wagner offered last night to join with Governor Dewey in the appointment of a commission to consider the advisability of giving the city a "proper share" of the unlimited taxing powers now exercised by the state.

He said the purpose of such a commission would be to "study all state aid with a view to abolishing it and returning to us the taxing powers from which the money is now obtained."

The Mayor's offer was made in an address on city finances at the annual public-service-awards dinner of the Citizens Budget Commission at the Plaza Hotel. He declared that his proposal looked to a long-range solution of the city-state fiscal problem and could not, in all probability, bear any fruit in time to help the city prepare its 1954-55 budget.

"I said almost a year ago," the Mayor declared, "that I was tired of the city going to Albany for a handout. I said that I agreed with the Governor—and this was in the winter of 1952-53—that the state should get out of the collection agency business. I added that as a substitute for it the state should return to the localities their proper share of the taxing powers themselves; that it should give us a decent share

PRESIDENT WOULD CUT SPENDING, KEEP SECURITY AND PROSPERITY, END CITIZENSHIP OF SUBVERSIVES

'AKIN TO TREASON'

Eisenhower Maps Plan
to Deal With Reds
Guilty of Plots

By W. H. LAWRENCE

SPECIAL TO THE NEW YORK TIMES.
WASHINGTON, Jan. 7.—President Eisenhower proposed today to strip United States citizenship from Communists convicted in the future of conspiring to advocate the overthrow of Government by force and violence.

His advocacy of a modern-day "men without a country" status for native-born or naturalized American conspirators surprised and delighted Congress.

The Communist conspiracy, the President said, is "akin to treason" and should be dealt with as such. Any person convicted of conspiring armed overthrow of Government, he proposed, should be "treated as having, by such act, renounced his allegiance to the United States and forfeited his United States citizenship."

This goes well beyond the present deprivation of civil rights suffered by those convicted of a felony. Under Federal law, those convicted of violating the Smith Act ban on conspiracy to advocate overthrow of the Government cannot vote, hold public



THE PRESIDENT REPORTS TO CONGRESS: President Eisenhower as he delivered his annual State of the Union message yesterday at a joint session of Congress. Behind him on the dais are Vice President Richard M. Nixon, left, and Speaker Joseph W. Martin Jr.

MESSAGE ON UNION

Eisenhower Proposes
Amendment to Give
18-Year-Olds Vote

Text of State of Union Message
is printed on Page 10.

By JAMES RESTON

SPECIAL TO THE NEW YORK TIMES.

WASHINGTON, Jan. 7.—President Eisenhower, in his second State of the Union Message, today asked the almost evenly divided Eighty-third Congress to moderate but sustain the foreign and welfare policies of the New Deal era.

He proposed to cut the military budget, to cut taxes in relation to Government expenditures, and to reduce the guarantees to farmers very slowly. The cuts, however, were designed to reconcile security and solvency without jeopardizing the collective security or prosperity policies of the past.

The message contained only two surprises.

One was an appeal for a law that would take away the citizenship of any American hereafter convicted in the courts of "conspiring to advocate the overthrow of this Government by force or violence."

Russian Is Turned Into English By a Fast Electronic Translator

By ROBERT K. PLUMB

A public demonstration of what is believed to be the first successful use of a machine to translate meaningful texts from one language to another took place here yesterday afternoon.

This may be the culmination of centuries of search by scholars for "a mechanical translator." So far the system has a vocabulary of only 250 words. But there are no foreseeable limits to the number of words that the device can store or the number of languages it can be directed to translate.

Scholars and scientists who worked on it believe that within a few years the system may greatly increase communication, particularly in technical subjects, by making translation quick, accurate and easy.

The demonstration was at the headquarters of the International Business Machines Corporation, 590 Madison Avenue. It is the result of cooperative research by

scientists of the corporation and scholars of the Georgetown University Institute of Languages and Linguistics in Washington.

The "mechanical" part of the translation system, which is mostly electronic, is a standard commercial model of the largest International Business Machines "stock" computer. This device, called the IBM Type 701 Electronic Data Processing Machine, was put on the market last April. Since then twelve of the machines have been sold to commercial, military and university computation laboratories.

The "literary" part of the system is a mechanical model of language devised at Georgetown by Prof. Leon Dostert and Dr. Paul Garvin. The corporation's share in the project was conducted by Dr. Cuthbert C. Hurd, director of its Division of Applied Science.

In the demonstration, a girl

Continued on Page 5, Column 2

NLP 的早期历史：1950 年代的机器翻译



AI 的起点：1956 年 Dartmouth 夏季研究项目



神经网络：来自神经元知识的启发

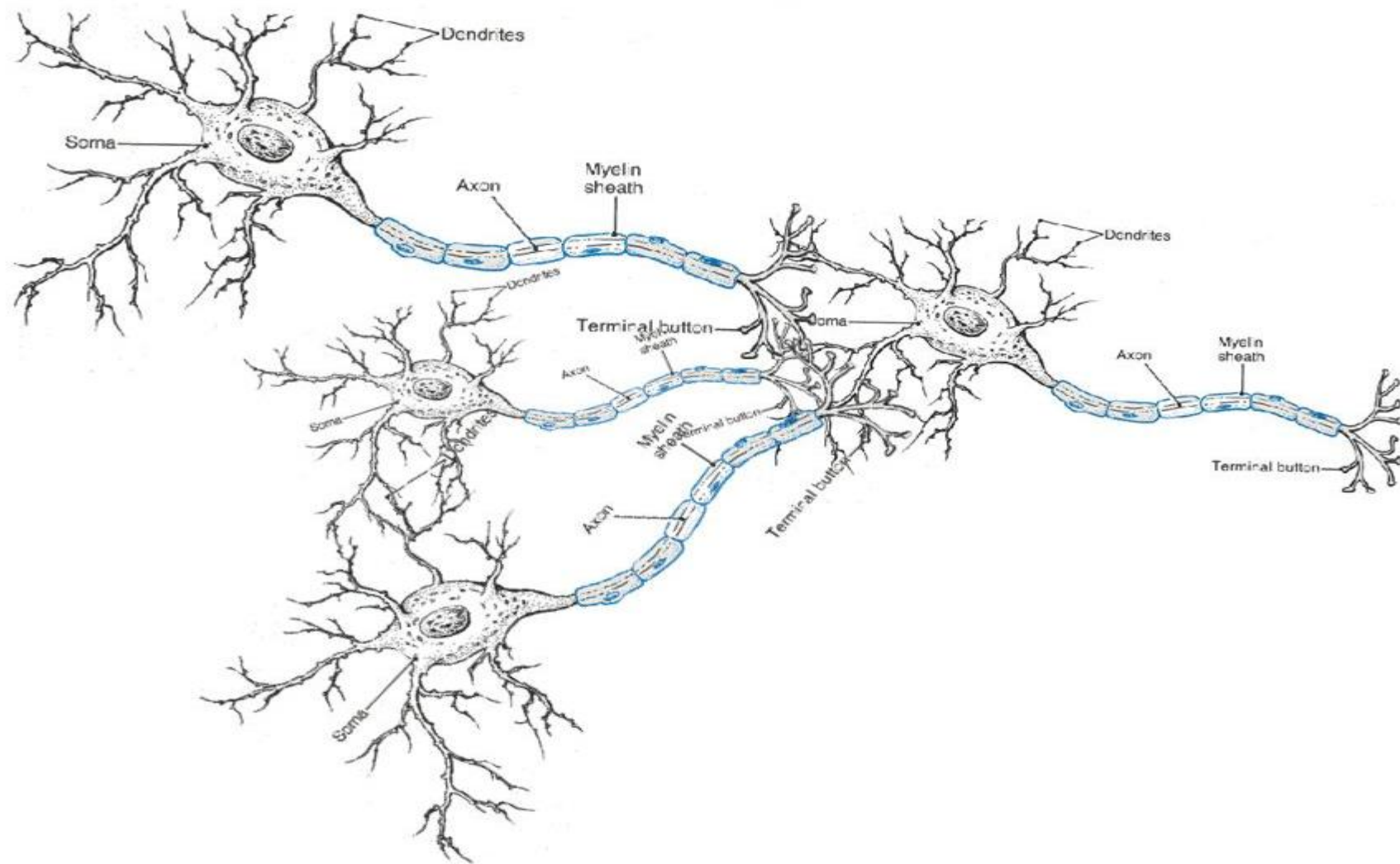

Warren S. McCulloch

and

Walter Pitts

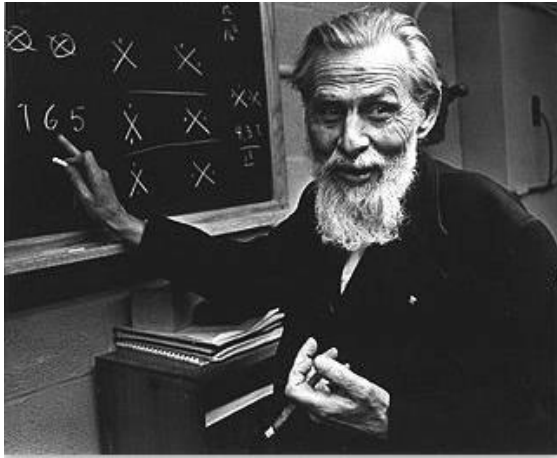

- 1898–1969. Neurophysiologist (MD), psychiatrist, and cyberneticist, moved to MIT in 1951 but Wiener split with him and Pitts in 1952.

- 1923 – 1969。自学成才的^{*}逻辑学家 computational neuroscientist, lived homeless at Chicago and then MIT; died 因酗酒去世。

In 1943, published “A Logical Calculus of Ideas Immanent in Nervous Activity”, the first 神经网络的数学模型，表明它可以实现图灵机

McCulloch - Pitts

神经元

Original McCulloch & Pitts

1943 阈值单元：

$$\mathbf{1}(Wx > \theta)$$

$$= \mathbf{1}(Wx - \theta > 0)$$

此函数没有斜率，

因此没有基于 `gradient` 的学习

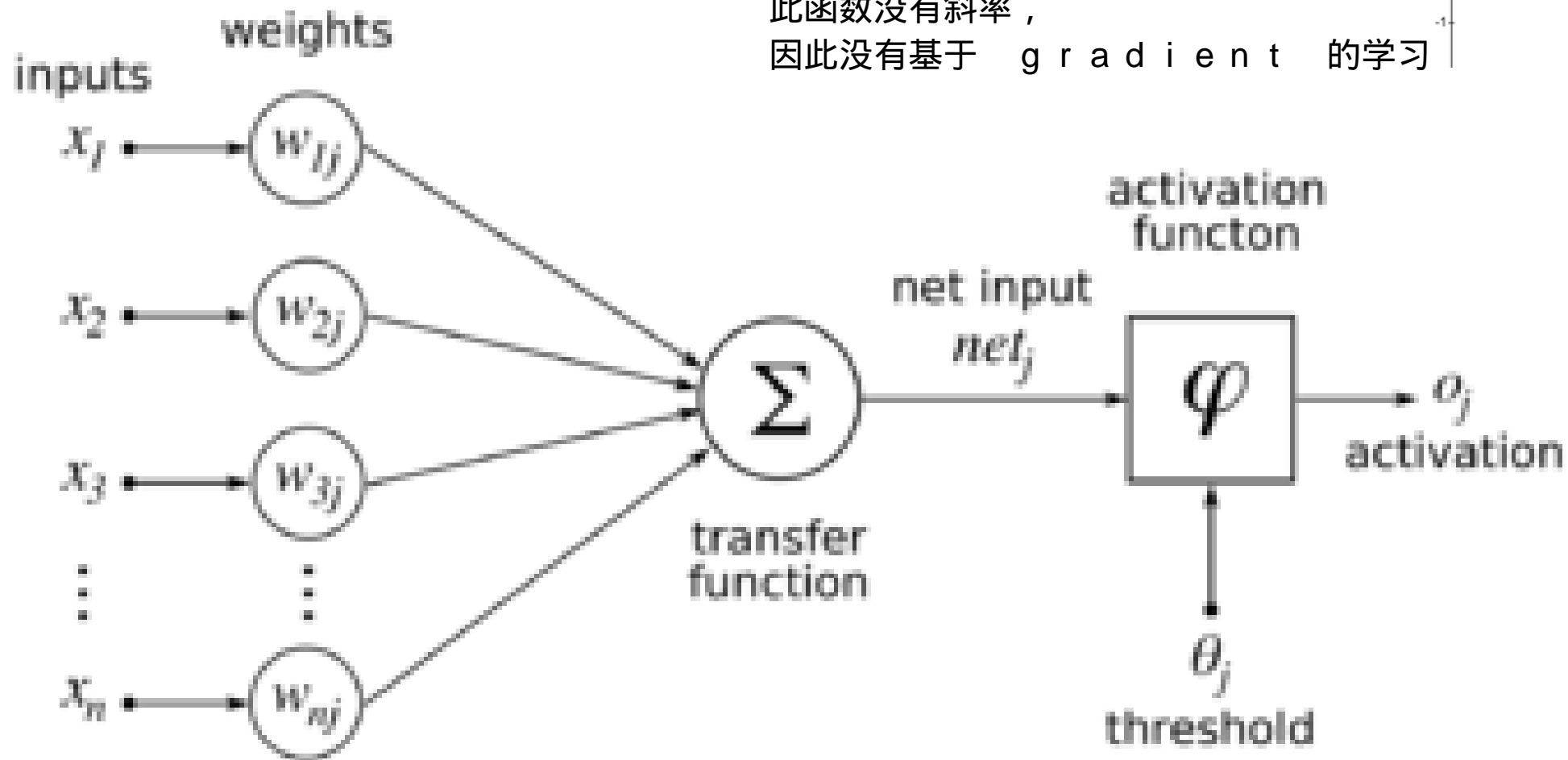
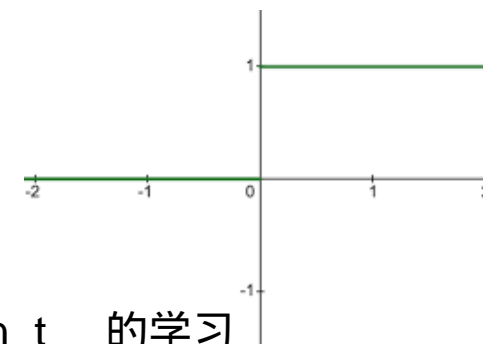

Frank Rosenblatt: (Mark I) 感知机

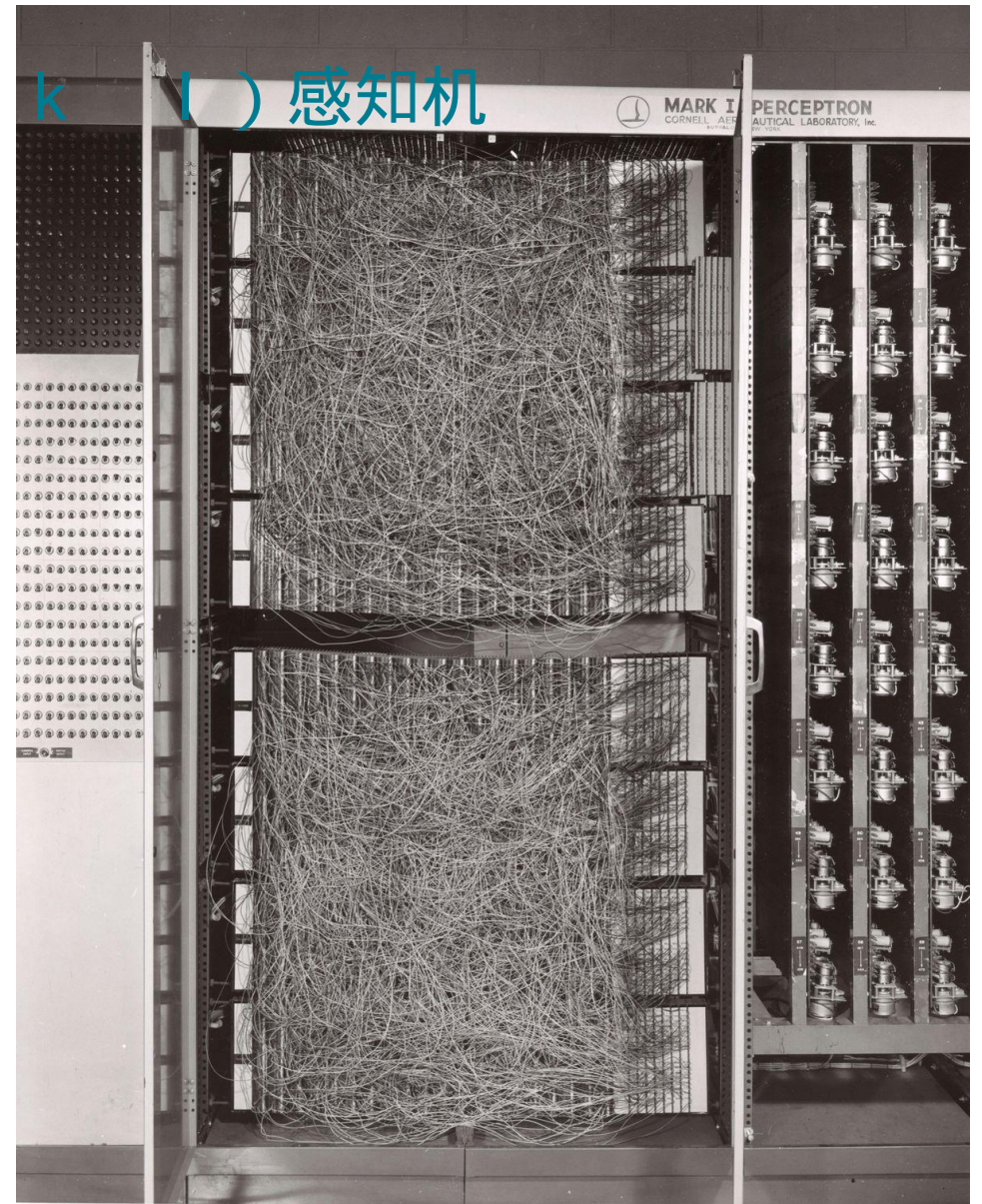

<https://news.cornell.edu/stories/2019/09/professors-perceptron-paved-way-ai-60-years-too-soon>



海军新装置通过实践学习

Psychologist Shows Embryo of Computer Designed 阅读并变得更智慧

The Navy revealed the embryo of an electronic computer today that it expects will be able to walk, talk, see, write, reproduce itself and be conscious of its existence.

The embryo—the Weather Bureau’s \$2,000,000 “704” computer—learned to differentiate between right and left after fifty attempts in the Navy’s demonstration for newsmen.

1950 年代人工智能的两种愿景

(符号主义) 人工智能

Minsky, McCarthy, Simon, Newell

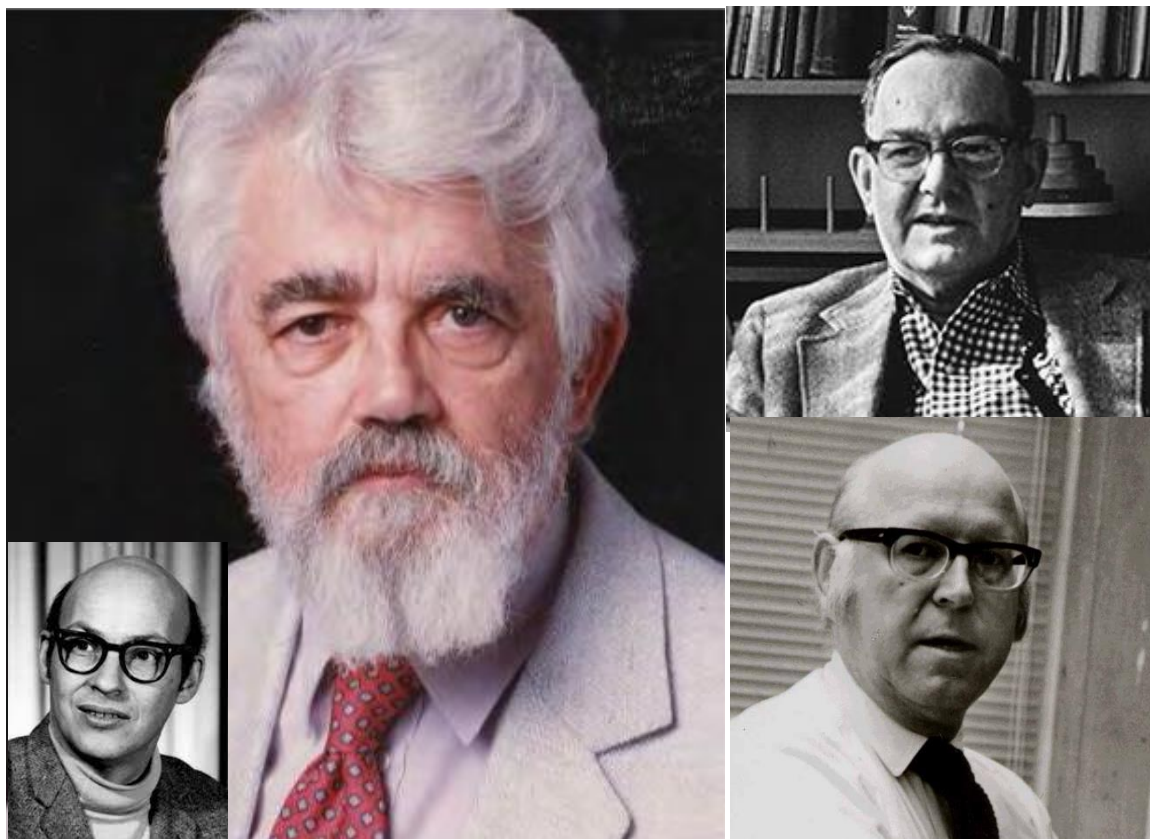

控制论

Wiener, Rosenblatt

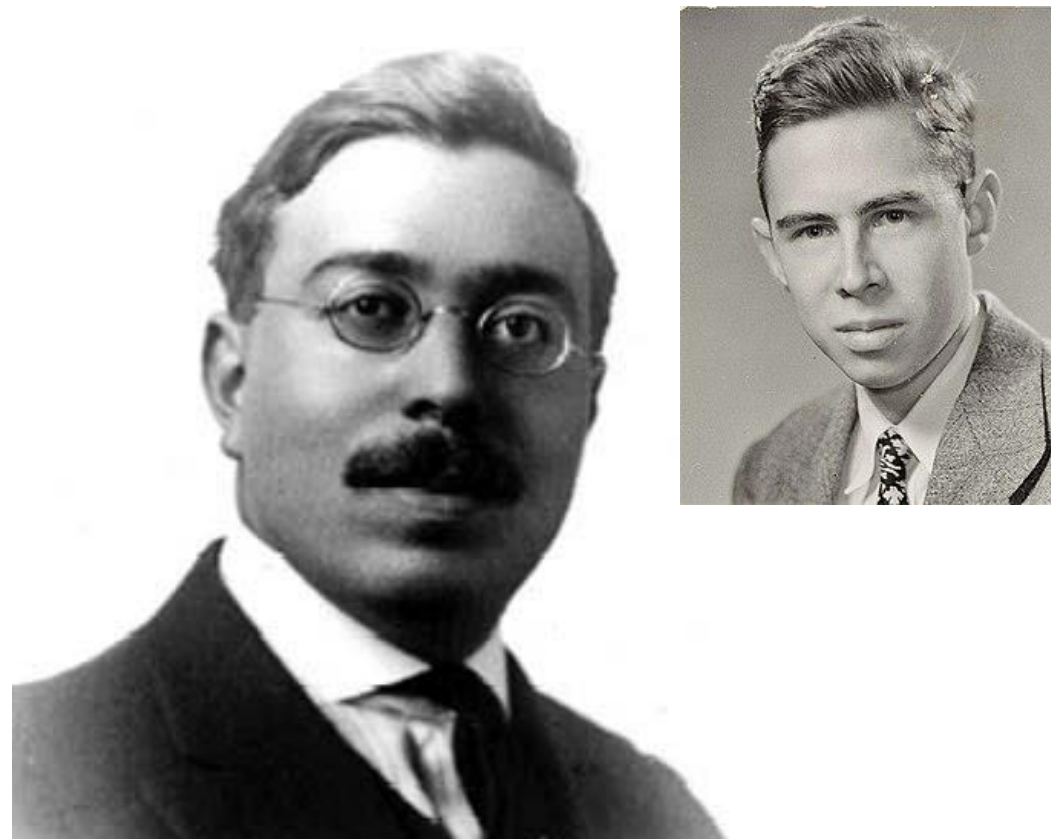

信息检索：Vannevar Bush

Bush (1945): As We May Think

“Consider a future device for individual use, which is a sort of mechanized private file and library. It needs a name, and, to coin one at random, “memex” will do. A memex is a device in which an individual stores all his books, records, and communications, and which is mechanized so that it may be consulted with exceeding speed and flexibility. It is an enlarged
其记忆的亲密补充。

<https://www.theatlantic.com/magazine/archive/1945/07/as-we-may-think/303881/>

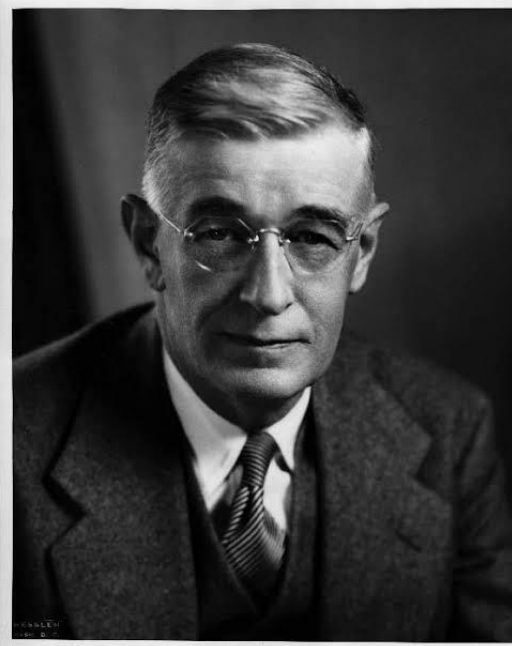

Bush went from being Dean of Engineering at MIT and president of the Carnegie Institution of Washington to chairman of the National Defense Research Committee in WWII (which had huge funding, directing all wartime science, including the Manhattan Project)

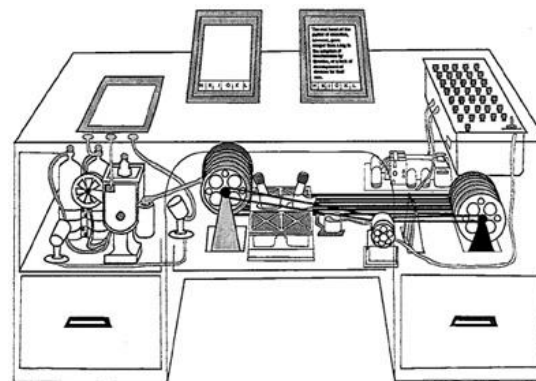

Cyril Cleverdon 引入了基准测试

- Cranfield 测试 (1957 - 1967)
- Defined the idea of **benchmark tests** for language, with a document collection, queries, and correct answers.
- He had exhaustive answers on document relevance over a small corpus!



NLP / 计算语言学的 1950 年代起源

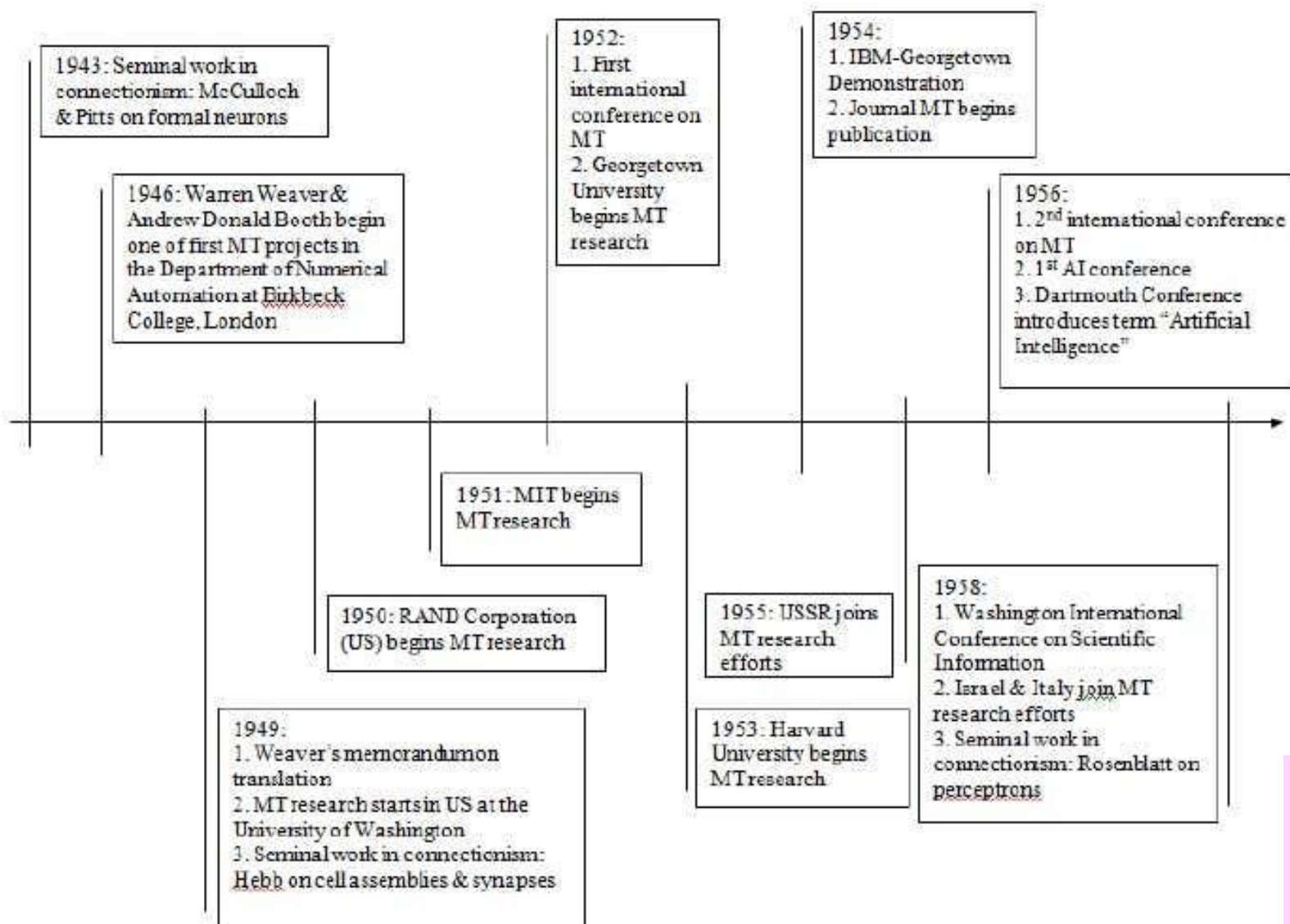

- Foundational work on automata, formal languages, probabilistic 建模和信息论
- 首批语音系统 (Davis 等人)
- 机器翻译受军方大力资助 — 过度自信
- But using machines dumber than a pocket calculator
- Little understanding of syntax, 语义学、语用学

I grabbed these timelines from Ruth Camburn's "A Short History of Computational Linguistics". She was a CSU Fresno Linguistics grad student around 2013.

1960s: David Glenn Hays: ACL founder and dependency parsing



Raj Reddy

(1937–, Stanford PhD student 1963–1966; faculty 1966–1969; CMU; Turing award)

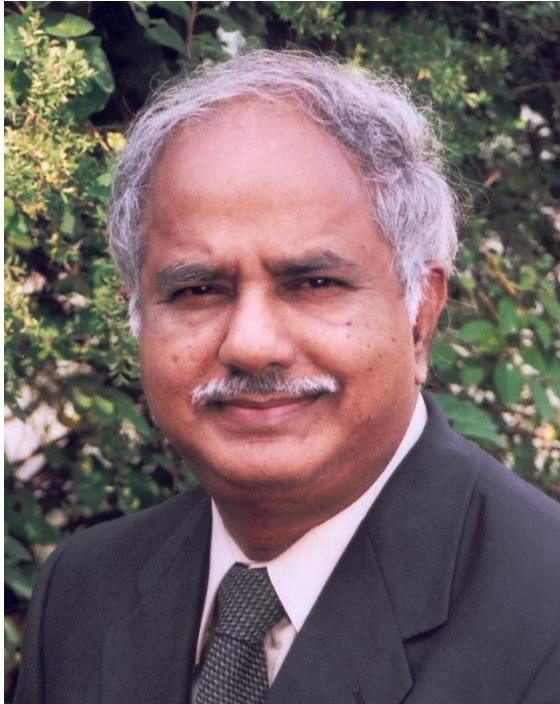

(部分) 学生：
James Gosling, Kai-Fu Lee,
Roni Rosenfeld, Alex Waibel



Joyce Friedman

(1 9 2 8 - 2 0 1 8 ; 1 9 6 5 - 1 9 6 8 年 在 S t a n f o r d)



cs -109

A COMPUTER SYSTEM FOR WRITING AND TESTING
TRANSFORMATIONAL GRAMMARS

FINAL REPORT

JOYCE FRIEDMAN
PRINCIPAL INVESTIGATOR

This research was supported in part by the United
States Air Force Electronic Systems Division, under
Contract F196828-C-0035.



C. Ray
Perrault
↓
James
Allen

David Scott
Warren



STANFORD UNIVERSITY COMPUTER SCIENCE DEPARTMENT
COMPUTATIONAL LINGUISTICS PROJECT

30 SEPTEMBER 1968



1960年代的 NLP

ALPAC report (1966):
天哪，这真的太难了！

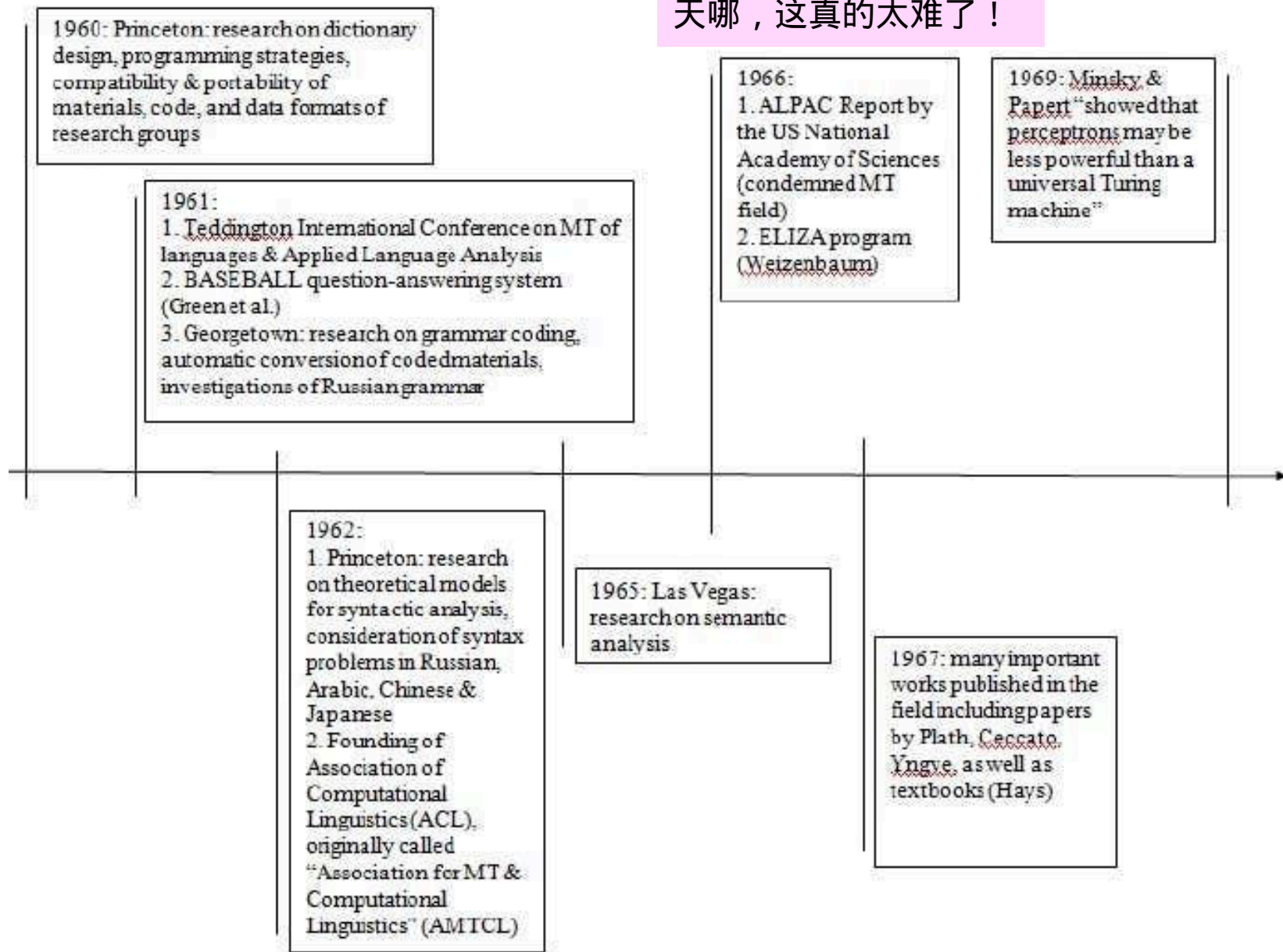

2. Hand-built demonstration NLP systems, of increasing formalization

1970–1992

Terry Winograd

(1 9 4 6 - , 1 9 7 3 - 2 0 1 4 年 S t a n f o r d 教授 ; 1 9 7 3 - 1 9 8 4 年从

Seymour Papert



Terry Winograd



Stuart Shieber

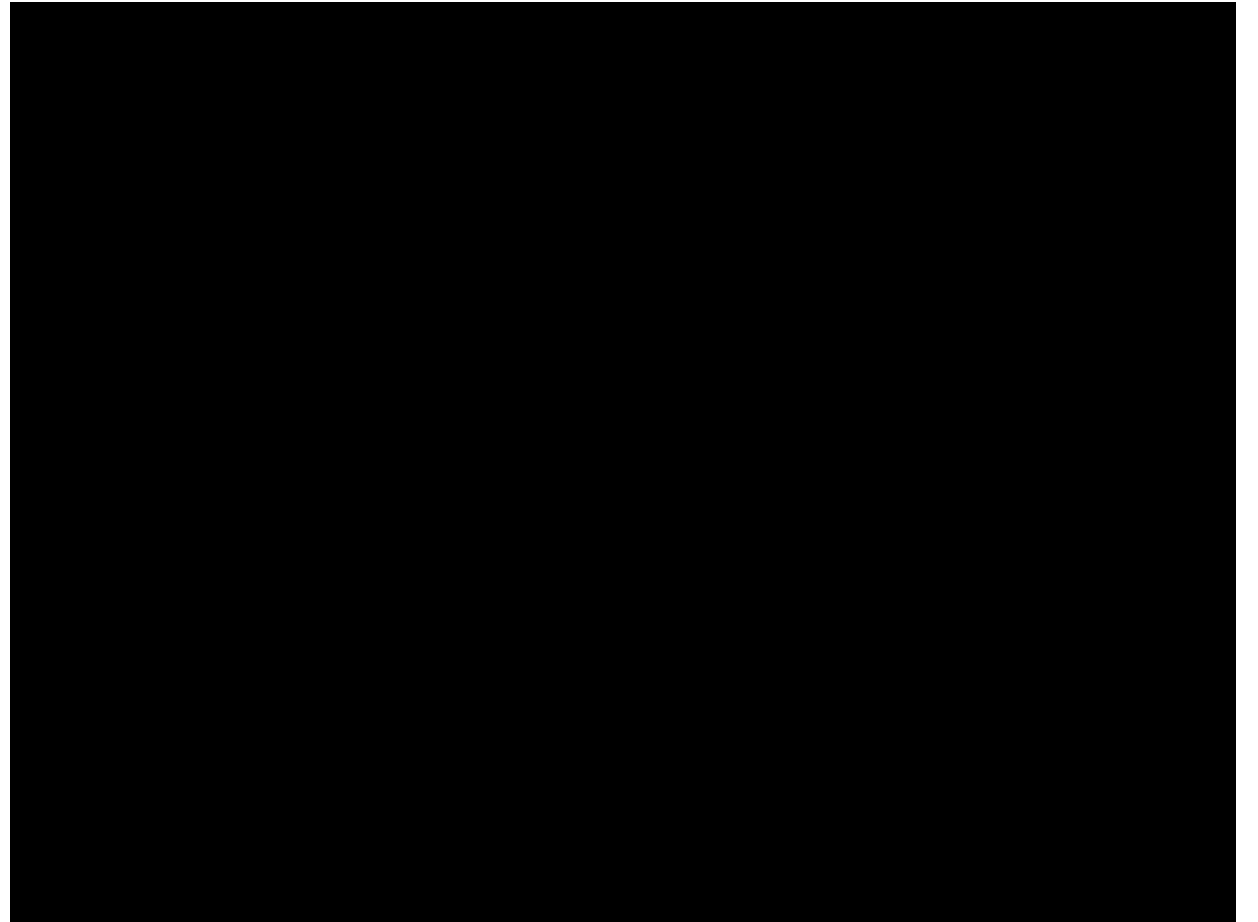
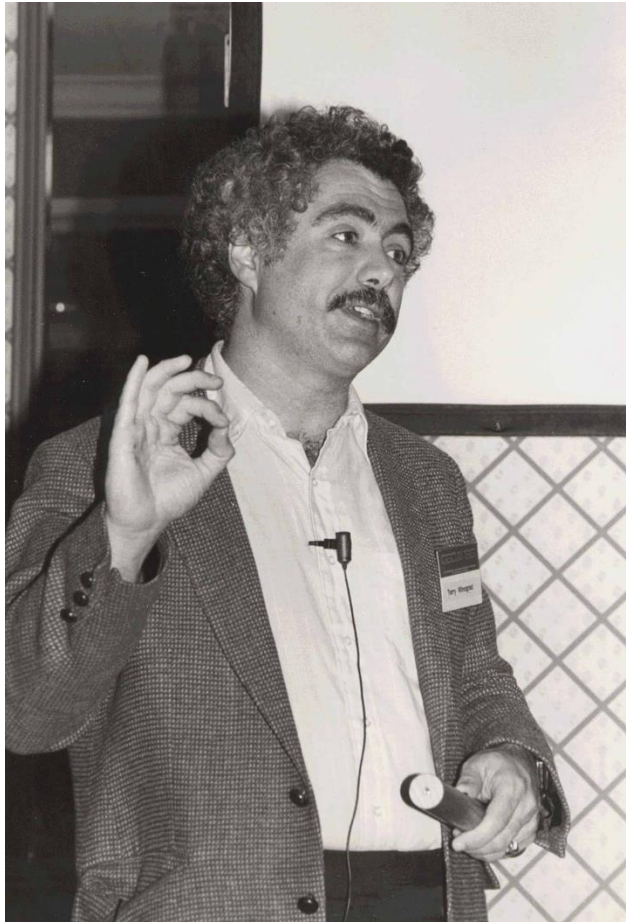

形式语法与合一语法在 NLP 中的应用：Martin Kay



Fernando Pereira



Stuart Shieber



构建人类语言的含义：1967-2017

- Tokenize a sentence into words: 红苹果在桌子上
- Parse it into a tree or graph data structure (using context-free grammars and beyond)
- Construct its meaning by: (i) lexical lookup, then (ii) semantic composition, using a “rule-to-rule” approach working up the tree (e.g., $PP: \alpha(\beta) \rightarrow P: \alpha NP: \beta$)

$on(\iota(\lambda x (apple(x) \wedge red(x))), \iota(\lambda y. table(y)))$

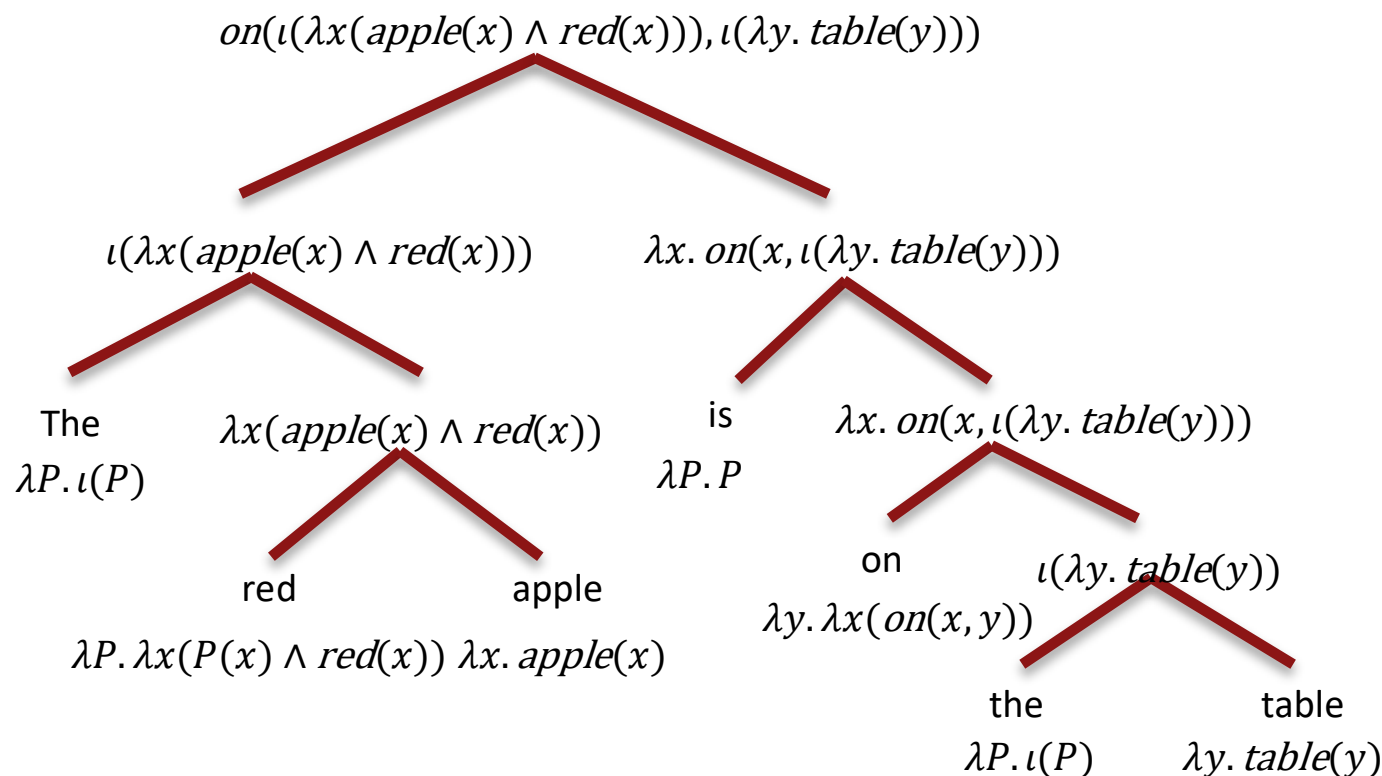

NLP 与知识表示：Norvig (1986) 博士

Peter Norvig's thesis: A Unified Theory of Inference for Text Understanding (1986)

A Unified Theory of Inference for Text Understanding
By
Peter Norvig
B.S. (Brown University) 1978

DISSERTATION
Submitted in partial satisfaction of the requirements for the degree of
DOCTOR OF PHILOSOPHY
in
COMPUTER SCIENCE
in the
GRADUATE DIVISION
OF THE
UNIVERSITY OF CALIFORNIA, BERKELEY



分析的语言：

In a poor fishing village built on an island not far from the coast of China, a young boy named Chang Lee lived with his widowed mother. Every day, little Chang bravely set off with his net, hoping to catch a few fish from大海中捕鱼，卖掉后能有一点钱买面包。

- (a) There is a sea, which surrounds the island, is used by the villagers for 捕鱼，并构成中国海岸的一部分
- (b) 张打算用他的网捕鱼，那是一张渔网
- (c) The word *which* refers to *the fish*
- (d) The word *they* refers to Chang and his mother

1970 和 1980 年代的 NLP

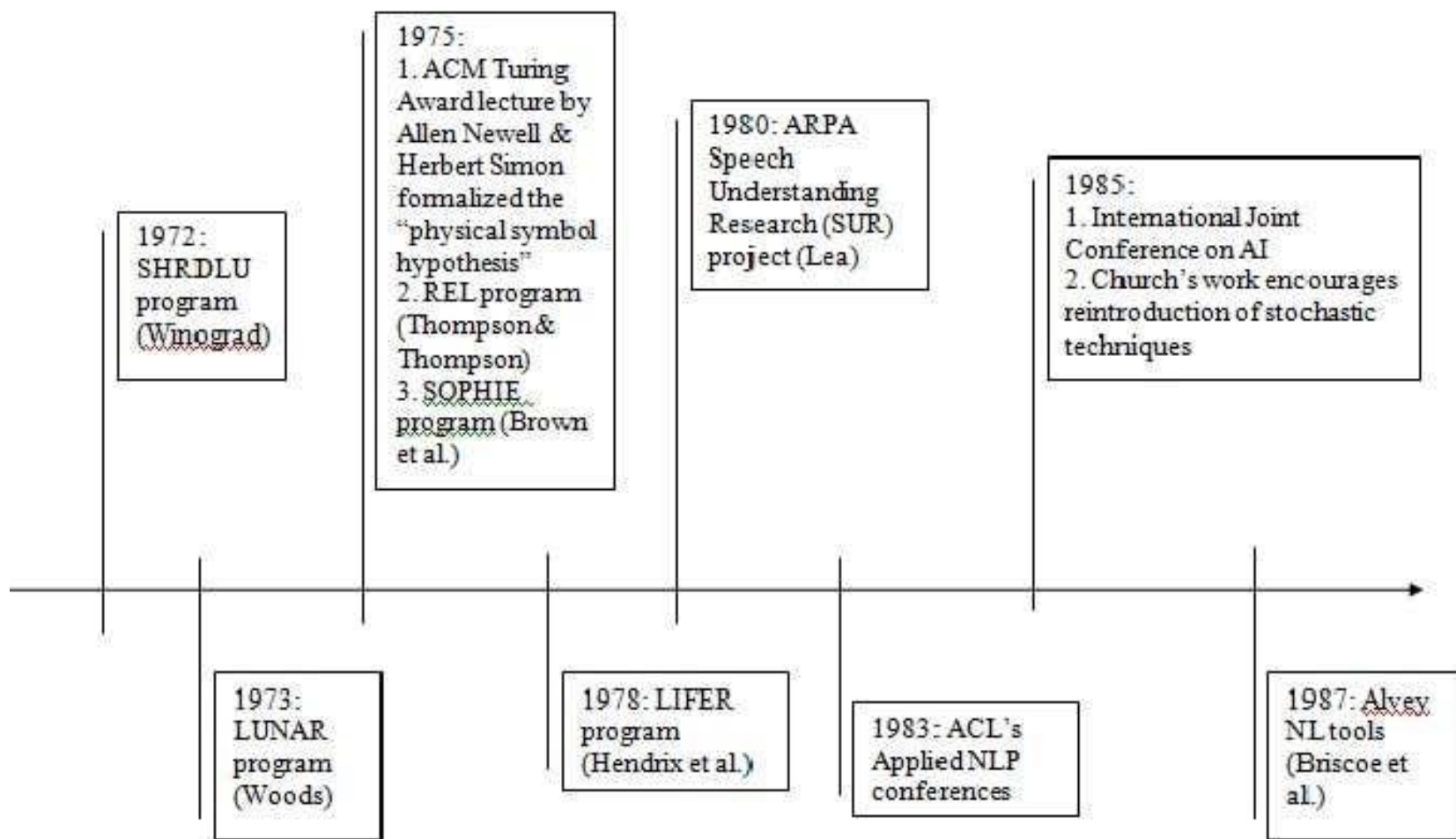

- Foundational work on speech recognition: stochastic modeling, hidden Markov models, the "noisy channel"
- Ideas from this work would 后来彻底改变了 NLP !
- 逻辑编程, 基于规则的 driven AI, deterministic algorithms for syntactic 句法分析 (如 LFG)
- Increasing interest in natural language understanding: SHRDLU, LUNAR, CHAT-80
- But symbolic AI hit the wall: "AI winter"

3. Statistical or Probabilistic NLP (“StatNLP”)

然后是更一般的有监督 ML 在 NLP 中的应用

1993–2012

Claude Shannon

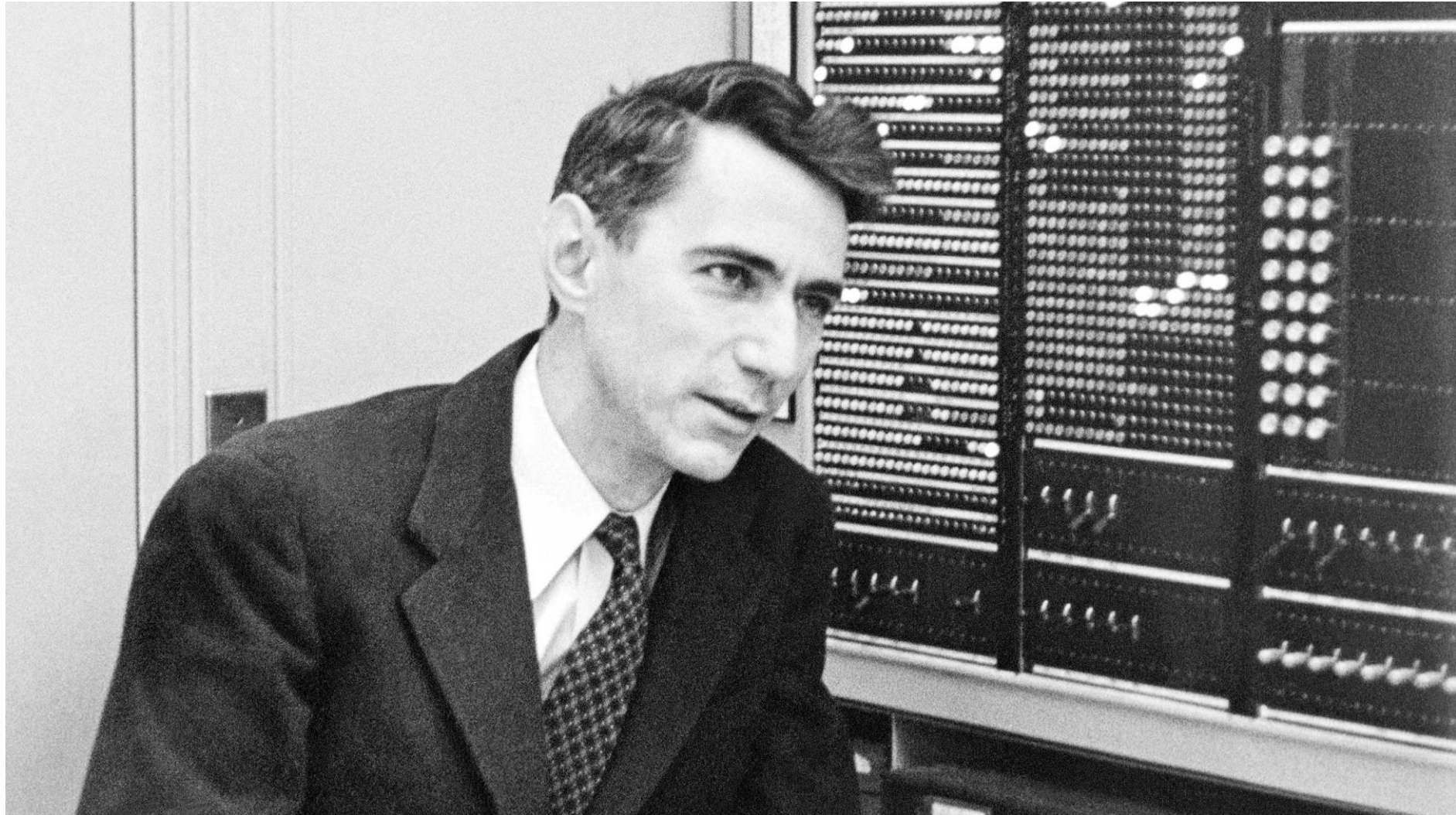

通信的数学理论 (1 9 4 8)

噪声信道模型

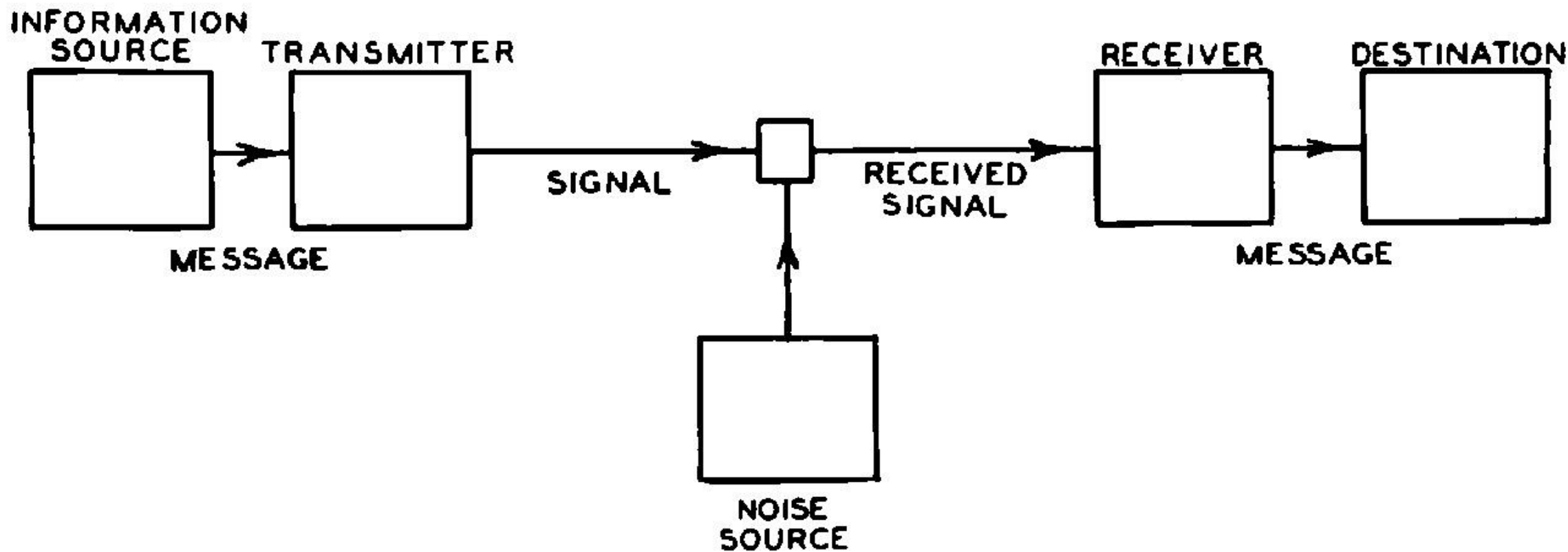

<https://www.quantamagazine.org/how-claude-shannons-information-theory-invented-the-future-20201222/>

统计革命：1990年代

- Influx of new ideas from EE & ASR: probabilistic modeling, 语料统计、有监督学习、实证评估
- New sources of data: explosion of machine-readable text; 人工标注的训练数据 (如 Penn Treebank)
- 标注数据 + 算法 + 概率预测
- Lowered expectations: forget full semantic understanding, let's do text cat, part-of-speech tagging, NER, and parsing!
- 工具: Naïve Bayes 分类器、HMM、PCFG、CRFS (CS228!)



Fred Jelinek

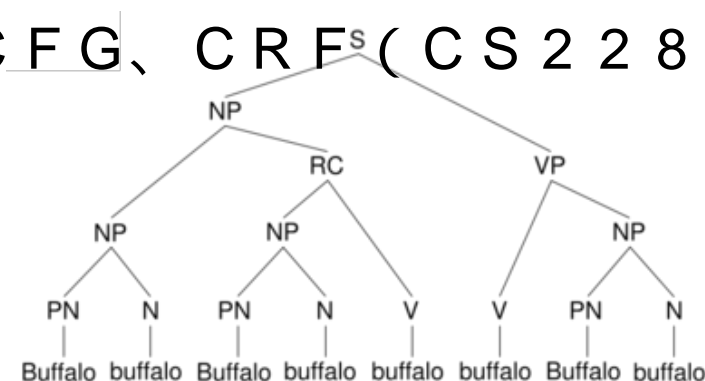
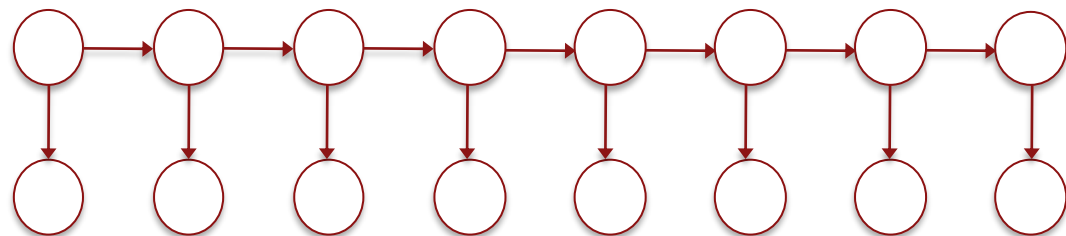

概率拼写纠正

"She is a stellar and versatile **acress** whose combination of sass and glamour attracts"

Let's estimate probabilities of corrections following one another

$$P(\text{actress}|\text{versatile}) = .0019$$

$$P(\text{across}|\text{versatile}) =$$

$$P(\text{whose}|\text{actress}) = .0043$$

$$P(\text{whose}|\text{across}) = .000026$$

$$P(\text{"versatile actress whose"}) = .00019 \times .0043 = 817,000 \times 10^{-10}$$

$$P(\text{"versatile across whose"}) = .000092 \times .000026 = 239 \times 10^{-10}$$

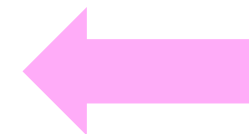

机器的崛起：2000年代

- 更强大计算机的出现
- 巩固统计革命的成果
- More sophisticated statistical modeling and machine learning algorithms: Max Ent, SVM, Bayes Nets, LDA 等
- 海量数据：互联网 100 倍增长，大型服务器集群
- Focus shifting from supervised to *unsupervised* 学习
- Revived interest in higher-level semantic applications



4 . D e e p L e a r n i n g 或人工神经网络在 N L P

4 a . 神经 N L P

2013–2021

Symbolic AI vs. “Cybernetics”

Stanford, the home of “Symbolic Systems”

- “Symbolic systems” studies systems of meaningful symbols that represent the world about us—like human languages, logics, and programming languages—and the systems that work with these symbols—like brains, computers, and complex social systems
 - While “cognitive science” focuses on the mind and intelligence as naturally occurring phenomena, 符号系统同等关注人类 - constructed systems that use symbols to 交流和表示信息

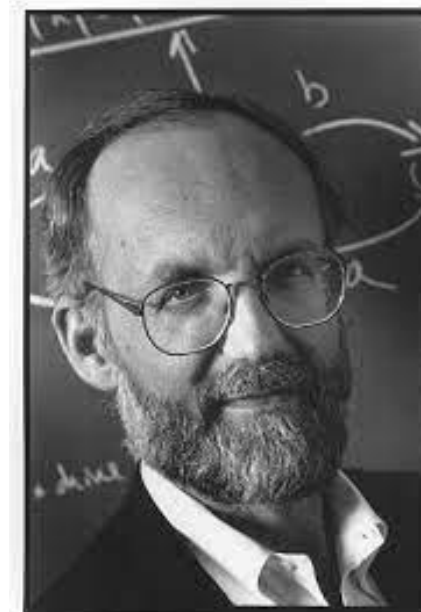
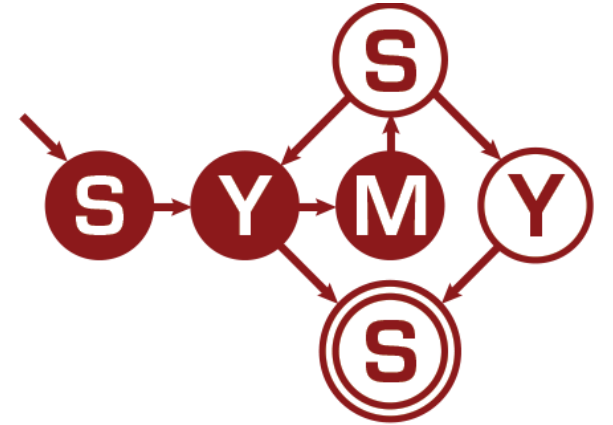

Jon Barwise

(1 9 4 2 – 2 0 0)

符号系统与其处理器

- Language is the symbolic system par excellence; we should study and make use of its 符号结构
- This does not show that the main processor of these symbols—the human brain—is 作为物理符号系统实现
- 我们无需将 NLP 系统设计为物理符号系统
- 大脑更像是一个神经网络模型
- Artificial neural network models scale better and can capture the world represented by 符号

cat

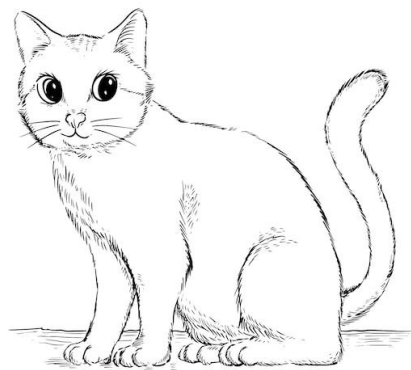

Hinton 的 Deep Learning 突破 ... at the University of Toronto, 2009–2012

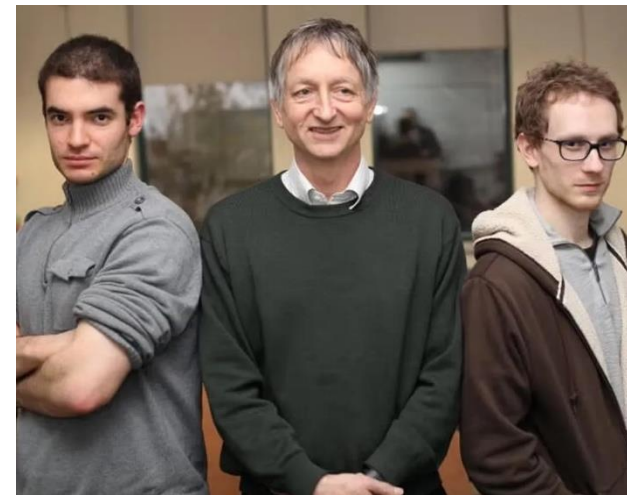
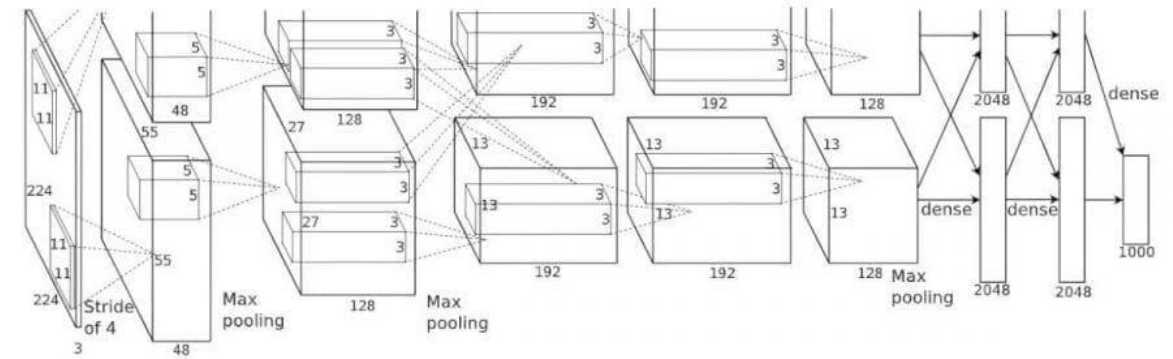
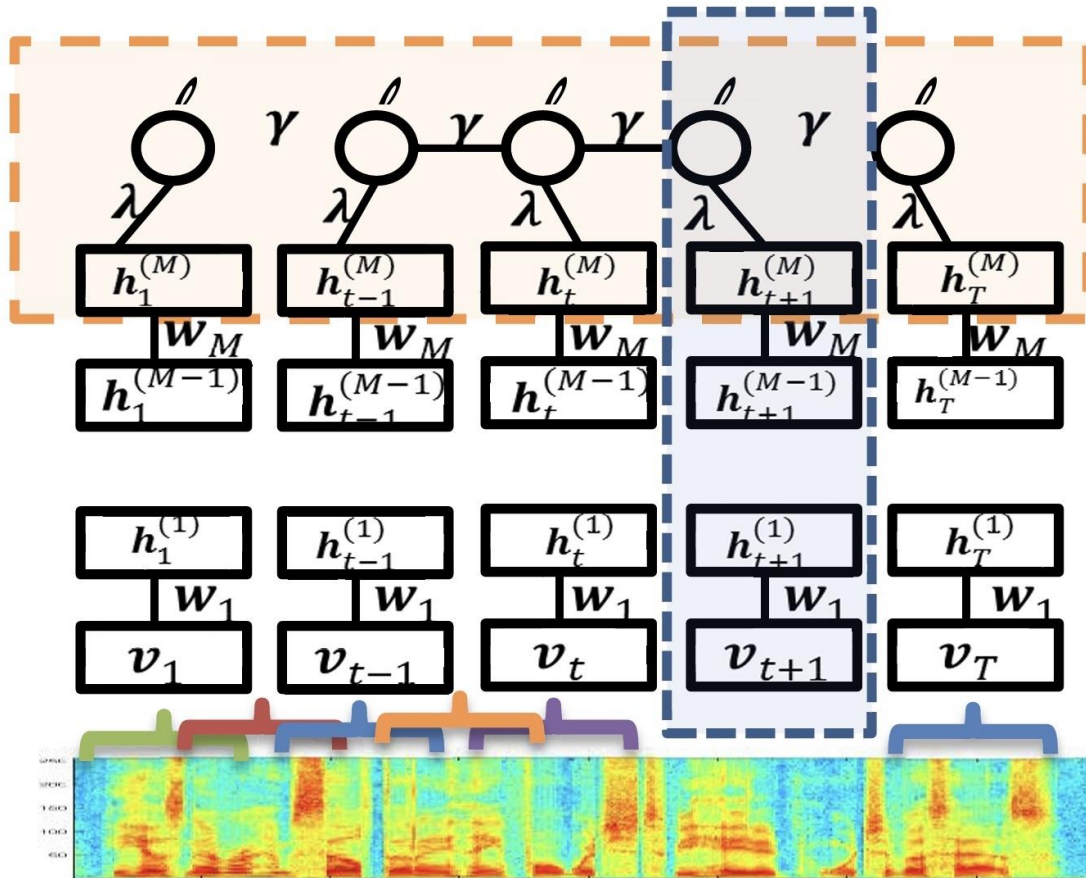

用于语音识别的 Deep Learning

- Speech recognition had first shown the breakthrough 概率方法的成功：HMM 和 GMM
- The first breakthrough results of “deep learning” on large datasets also happened in 语音识别
- George Dahl et al. (2010/2012): Context-Dependent Pre-trained Deep Neural Networks for Large Vocabulary Speech Recognition

Acoustic model \ WER	RT03S FSH	Hub5 SWB
传统 GMM (D. 等人 2011)	27.4	23.6
Deep Learning (Dahl et al. 2010)	18.5 (-33%)	16.1 (-32%)
Deep Learning (Sainath et al. 2012)	8.9 (-67%)	5.5 (-77%)

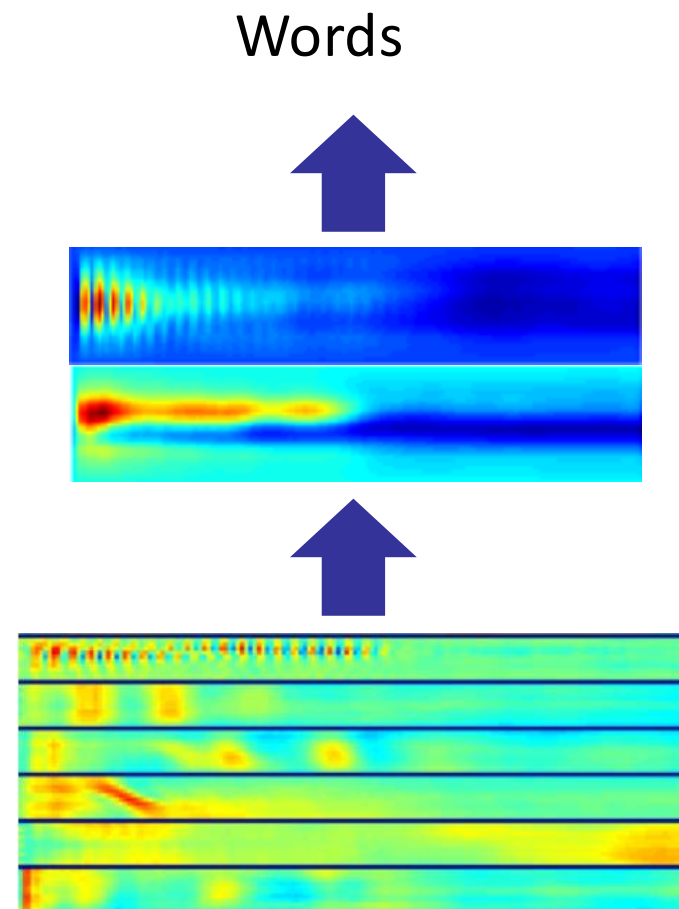

“(Artificial) neural (network)” or “deep learning” models for word meaning

我们学习将一个词表示为数字向量

$$\textit{versatile} = \begin{pmatrix} 0.286 \\ 0.792 \\ -0.177 \\ -0.107 \\ 0.109 \\ -0.542 \\ 0.349 \\ 0.271 \end{pmatrix}$$

相似向量 = 相似含义

通过分布相似性学习向量



我们如何学习这些 `w o r d v e c t o r s` ?

“You shall know a word by the company it keeps” (J. R. Firth 1957: 11)

任何带有浏览器的设备，从笔记本和平板到智能手机
用户可以从 `M i c r o s o f t U p d a t e` 网站为家用电脑或笔记本下载

↖ These words will represent *laptops* ↗

Defining similarity via contextual distributions in texts is one of the most successful ideas
现代计算语言学的

一个 RNN encoder-decoder 网络

Encoder

Decoder

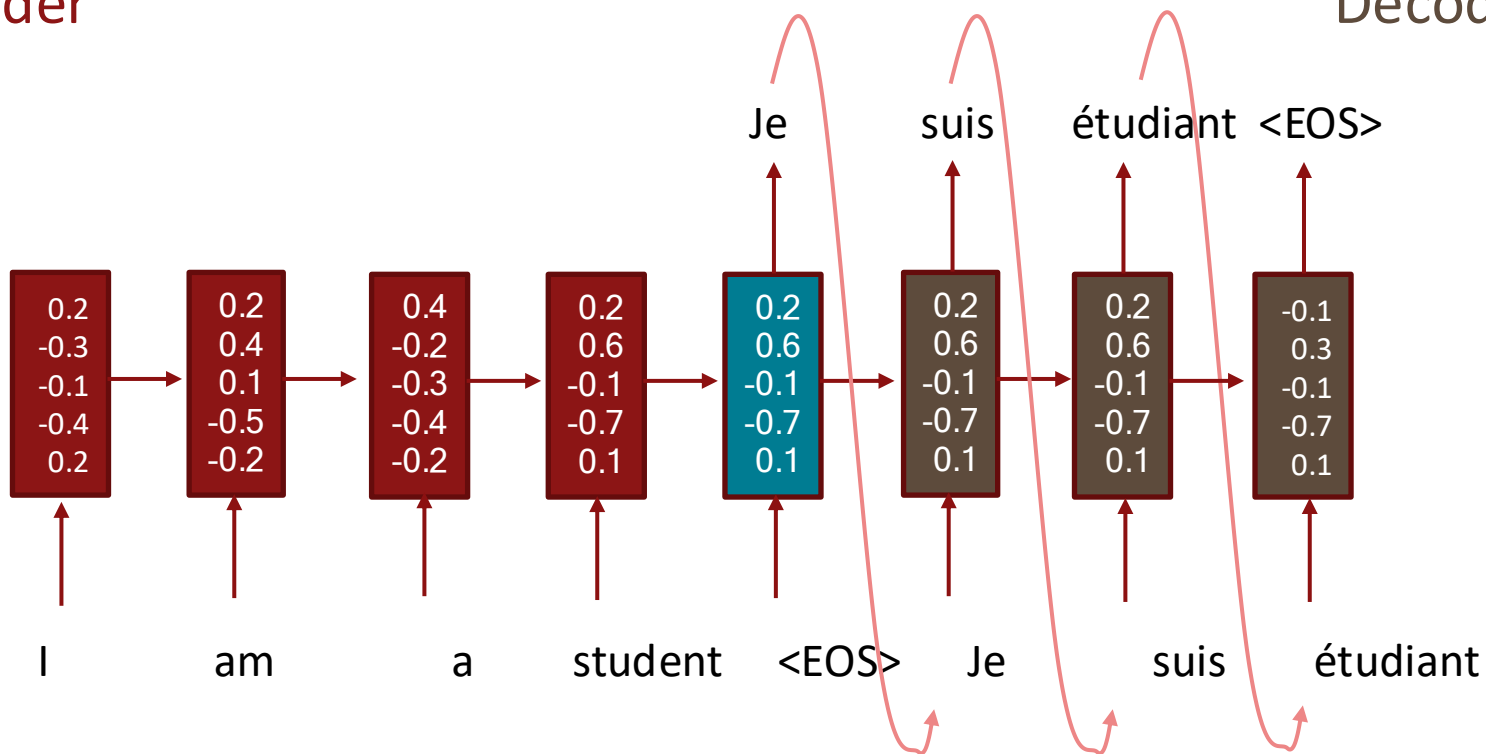

$$h_t = \tanh(W[x_t] + Uh_{t-1} + b)$$

一个 LSTM encoder - decoder 网络

[Sutskever et al. 2014]

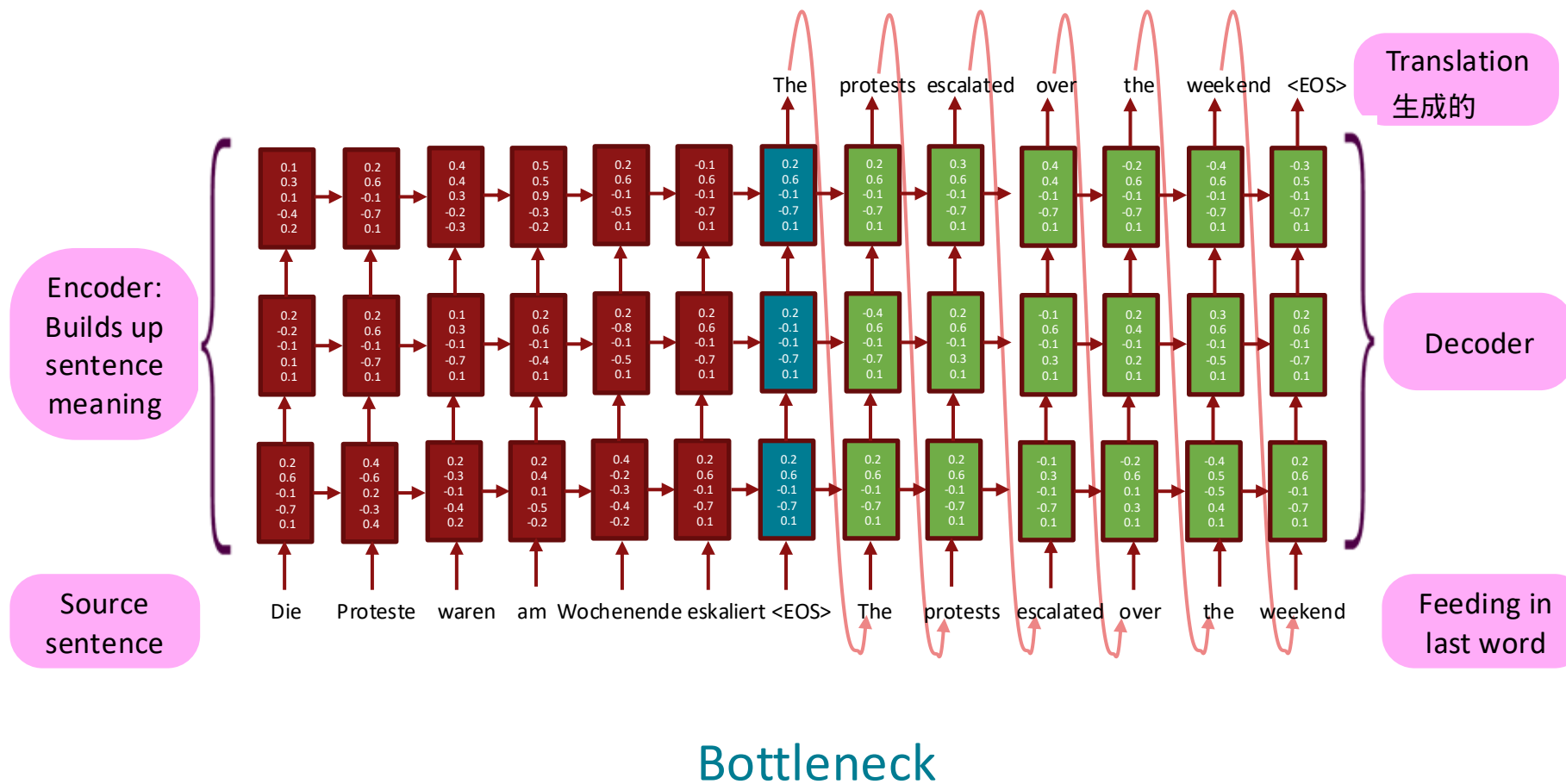

机器翻译随时间的进展

[Edinburgh En-De WMT newstest2013 Cased BLEU; NMT 2015 from U. Montréal]

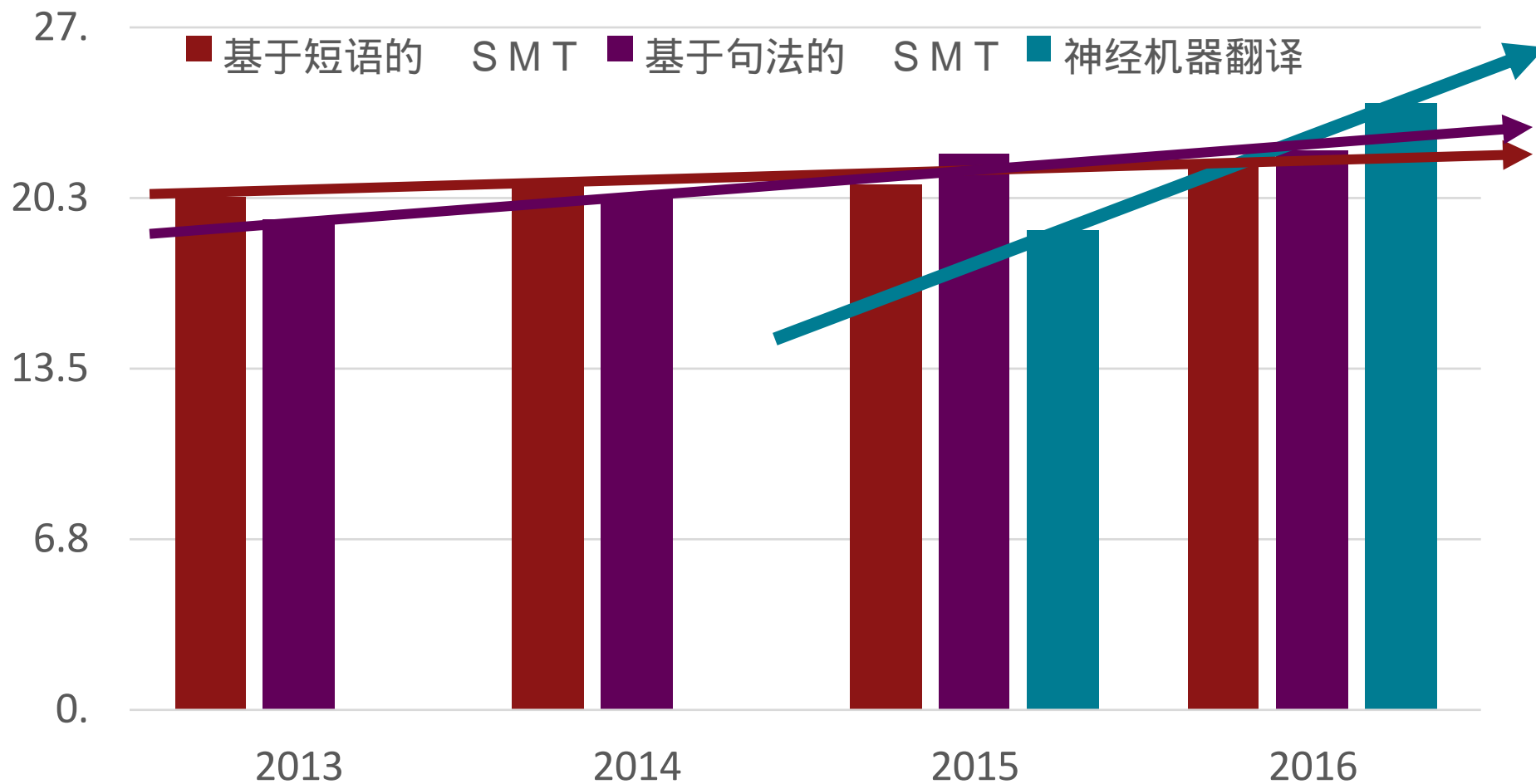

Source: http://www.meta-net.eu/events/meta-forum-2016/slides/09_sennrich.pdf

On Google Neural MT, see: <https://www.nytimes.com/2016/12/14/magazine/the-great-ai-awakening.html>

4 . D e e p L e a r n i n g 或神经网络在 N L P

4 b . 大语言模型

2022–present

The Rise of Generative AI: S&P 500 Companies Discussing "AI"

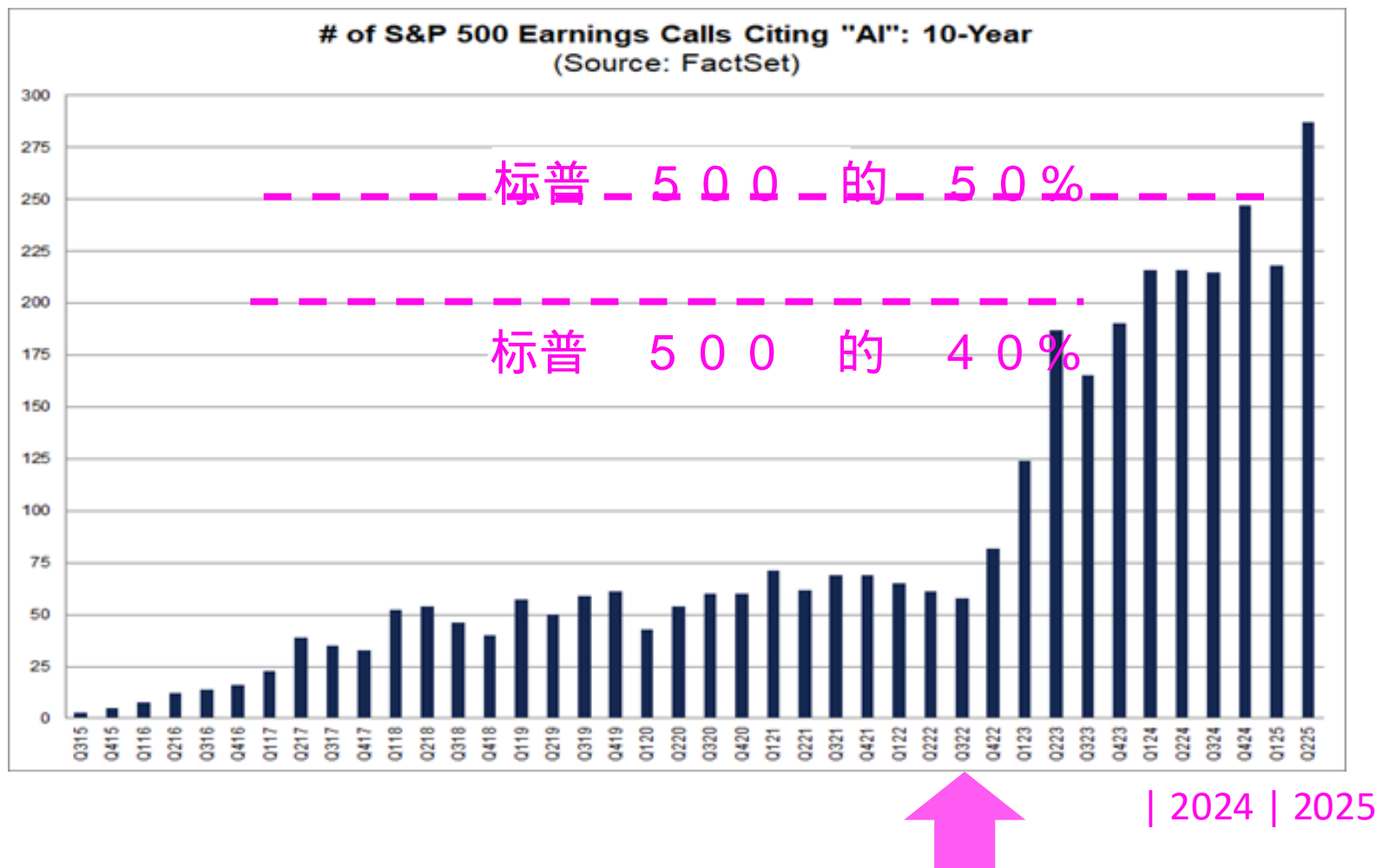

ChatGPT 发布

Large Language 模型

Source: GPT 4o

An abstract image in pastel manga style of a large language model as a big machine that takes in text and produces fresh writing on an endless scroll and which is maintained by a large number of scientists and engineers.

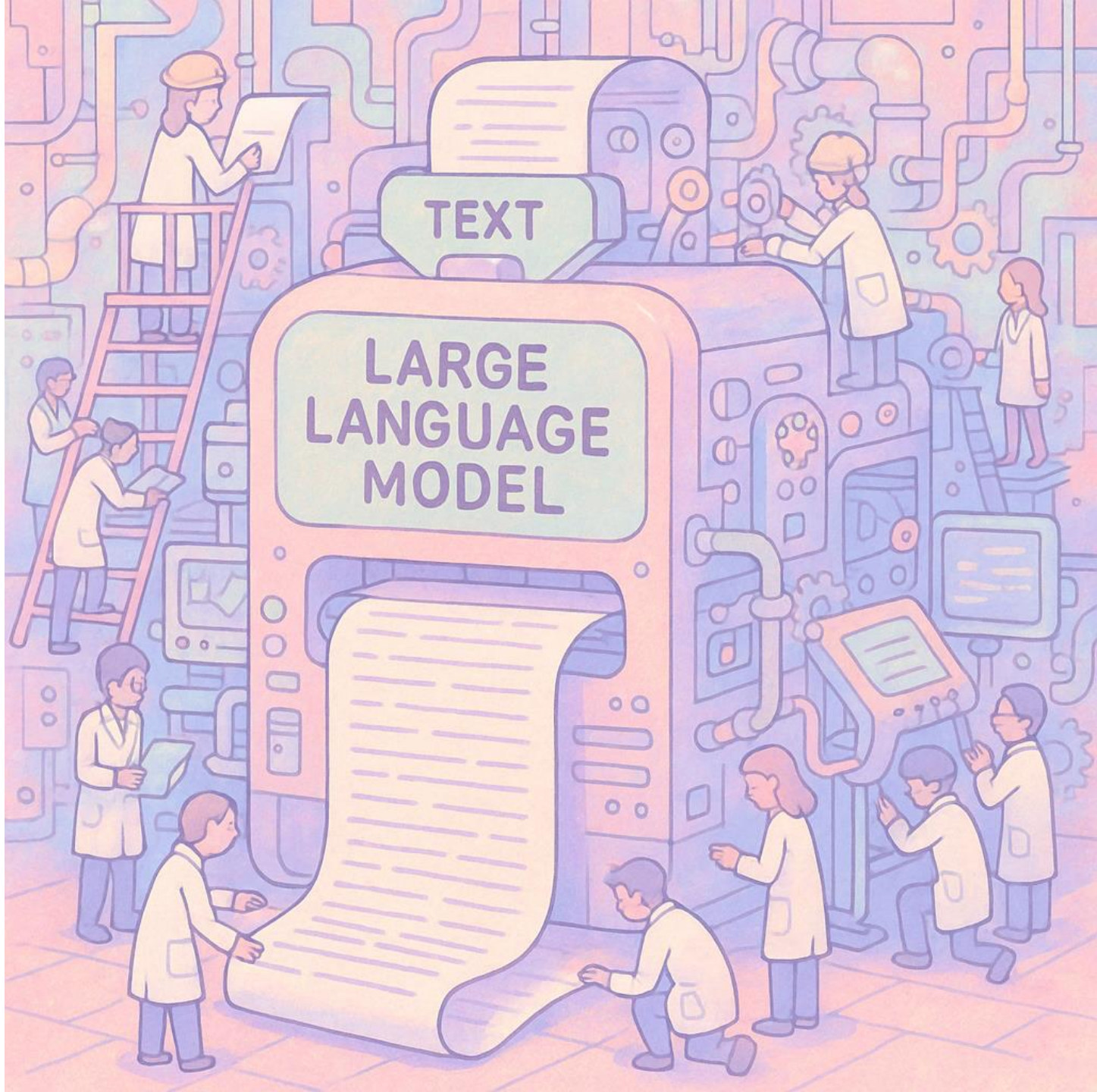

语言模型的历史

1913 Andrey A. Markov explores consonant-vowel transition probabilities in Alexander Pushkin novel, *Eugene Onegin*, developing Markov Models



1948 Claude E. Shannon develops 信息的数学理论 ; explores character/word-level n -gram models, entropy, text generation



1975 Frederick Jelinek's group at IBM defines and names the modern concept of a (probabilistic) "language model" for next token prediction. 用于拼写纠正、语音识别、机器翻译.....



But this technology wasn't considered a pathway to machines with artificial intelligence: For that we needed models of memory, knowledge representations, planning systems, 以及对抽象概念的推理

大语言模型的历史

- 1998 CPAT-Tree-Based Language Models with an Application for Text Verification in Chinese. ROCLing 1998. First use of “LLM” trigram I know of; 200M word corpus
- 2000 神经概率语言模型。B e n g i o , D u c h a r m e & V i n c e n t N I
首个神经语言模型，基于 3 2 0 0 万 t o k e n 语料库构建，词表 3 1 K
- 2007 Large Language Models in Machine Translation. Brants, Papat, Xu, Och and
Dean. EMNLP 2007. 2 万亿 t o k e n 语料库
n-gram model of up to 5-grams
- 2018 **GPT** (Radford, Narasimhan, Salimans & Sutskever) and **BERT** (Devlin, Chang,
Lee & Toutanova). 3.3 billion token corpus
- 2020- 1 0 0 0 亿 + 参数的神经语言模型，在超过 1 万亿 t o k e n 上训练：
GPT-3, GPT-4, PaLM 2, Llama 3, Nemotron-4,

大语言模型的历史

1998 CPAT-Tree-Based Language Models with an Application for Text Verification in Chinese. ROCLing 1998. First use of “LLM” trigram I know of; 200M word corpus

2000 神经概率语言模型。Bengio, Ducharme & Vincent N I
首个神经语言模型，基于 3200 万 token 语料库构建，词表 31K

2007 Large Language Model. Och and
Dean. EMNLP 2007 2 万亿 token 语料库
模型灵活性！
5-grams

2018 GPT (Radford, Narasimhan, et al., 2019; Brown, et al., 2020; Lee & Toutanova). 3.3 bil
Not enough 数据！

2020- 1000 亿 + 参数的神经语言模型，在超过 1 万亿 token 上训练：
GPT-3, GPT-4, PaLM 2, Llama 3,

ChatGPT 4o

Write a sonnet praising Wikipedia in which each line begins with the letter W

Wikipedia: A Sonnet of Wonder

With wisdom vast, it spans the world so wide,
Wielding the wealth of knowledge, free to share.
Words weave through time where curious minds confide,
Whispering truths with patience, just and fair.
Wondrous it stands, a beacon shining bright,
Warding off darkness, doubt, and false pretense.
Wrought by the hands of many, day and night,
Witness to learning's boundless recompense.
Who dares to claim the heights of thought alone?
Whence comes this trove but hearts in concert joined?
While scholars build on stones that others've known,
Waking the past, their voices intertwine.
Wisdom and will sustain this noble dream,
Wikipedia—our light, our endless stream.

使用 GPT - 4 的顾问表现优于未使用者

- Consultants (from Boston Consulting Group) using GPT-4 finished **12.2%** 更多任务 on average, **completed** 快 25 . 1 % 完成任务 and 产生的 **40% higher quality** 结果 than those not using AI
- Use of an LLM particularly improved the performance of lower-performing 人类
- 结果因任务而异
 - Dell'Acqua et al. 2023; Mollick 2023



Distribution of output quality across all tasks. Blue group did not use GPT-4; green 红色组使用了 GPT - 4 ; 红色组还接受了如何使用 AI 的额外培训。

Can GPT-4 write fiction that matches the quality of *New Yorker* fiction?

好消息！不能！（至少在 2023 年……）

GPT-4 在创意写作方面仍然差 3 - 10 倍！

Art or Artifice? Large Language Models and the False Promise of Creativity

TUHIN CHAKRABARTY, Columbia University, USA

PHILIPPE LABAN, Salesforce AI Research, USA

DIVYANSH AGARWAL, Salesforce AI Research, USA

SMARANDA MURESAN, Columbia University, USA

CHIEN-SHENG WU, Salesforce AI Research, USA

Researchers have argued that large language models (LLMs) exhibit high-quality writing capabilities from blogs to stories. However, evaluating objectively the creativity of a piece of writing is challenging. Inspired by the Torrance Test of Creative Thinking (TTCT) [61], which measures *creativity as a process*, we use the Consensual Assessment Technique [3] and propose *Torrance Test of Creative Writing* (TTCW) to evaluate *creativity as product*. TTCW consists of 14 binary tests organized into the original dimensions of Fluency, Flexibility, Originality, and Elaboration. We recruit 10 creative writers and implement a human assessment of 48 stories written either by professional authors or LLMs using TTCW. Our analysis shows that LLM-generated stories pass 3-10X less TTCW tests than stories written by professionals. In addition, we explore the use of LLMs as assessors to automate the TTCW evaluation, revealing that none of the LLMs positively correlate with the expert assessments.

<https://arxiv.org/abs/2309.14556>

自然语言处理的历史

CS224N/Ling284

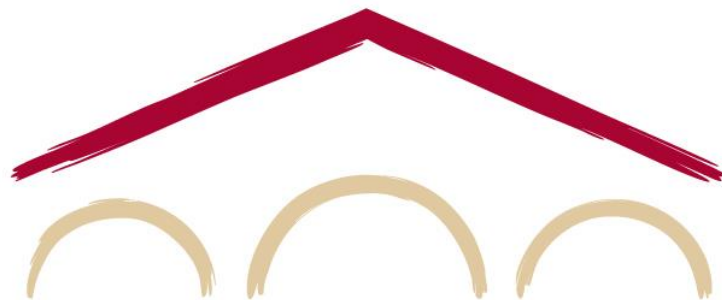

Christopher Manning

Lecture 1